

Tre Thermostatic Valve Item #2845

Features:

- Built-in thermostatic valve
- Includes rough-in and trim
- Brass construction with thermostatic cartridge
- Mixing valve cycles from cold to hot water
- Anti-scald protection & temperature regulation for flow rates as low as 2.4 GPM
- 3/4" Female NPT inlets & outlet
- Flow rate: 15 GPM Max at 43.5 PSI

Recommended Accessories:

- Item #2860: Built in stop valve with knob handle and backplate



Finish Options:

CR - Polished Chrome

Parts:

- R039 - Replacement thermostatic cartridge
- R2845-EX - Extension kit

Product Specifications:

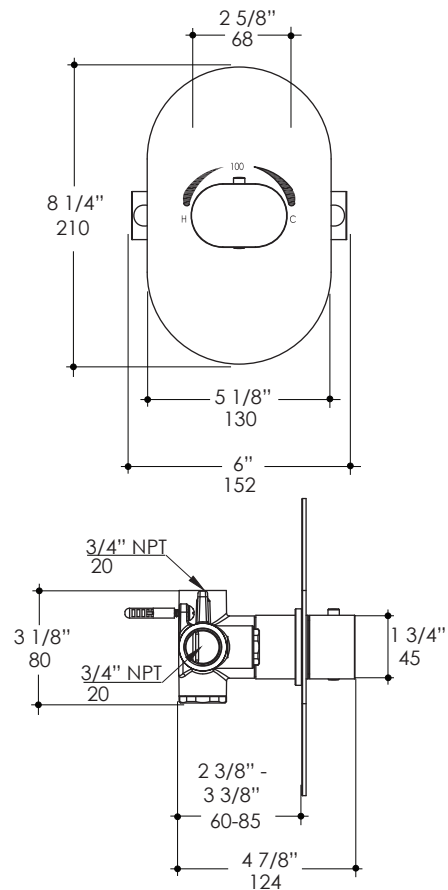

Notes:
 Drawings provided herein are meant to give the user an idea of the product and are not made to scale. The size in inches is rounded up to the nearest 1/16".
 Plumbing specifications are only a guideline and may need to be altered based on the application.
 Product specifications are not binding to the manufacturer and can be changed without notice at any time. Please refer to your shipment for product final sizes.

LACAVA is committed to the highest level of customer service. Please feel free to contact us at 1-888-522-2823 (toll free) or by email at info@lacava.com for technical assistance or any general inquiries.

Rev. 2-18-2013