

## Kubista Pressure Balancing Mixer Item #1440

### Features:

- Built-in pressure balance valve with lever handle and backplate
- Brass construction with single ceramic disc cartridge
- Includes rough-in and trim
- Mixing valve cycles from cold to hot water
- Anti-scald protection & temperature regulation for flow rates as low as 2.4 GPM
- Screwdriver service stops
- 1/2" Female NPT inlets & outlet
- Flow rate: 4.8 GPM at 43.5 PSI
- Complies with the following standards/codes:
  - ADA
  - cUPC/IAPMO
  - ASME A112.18.1/CSA B125.1-2005
  - CMR 248 (Mass. Code of Approval)



### Finish Options:

CR - Polished Chrome

### Parts:

R037 - Replacement ceramic cartridge  
R1440EX - 1 3/16" extension kit

### Product Specifications:

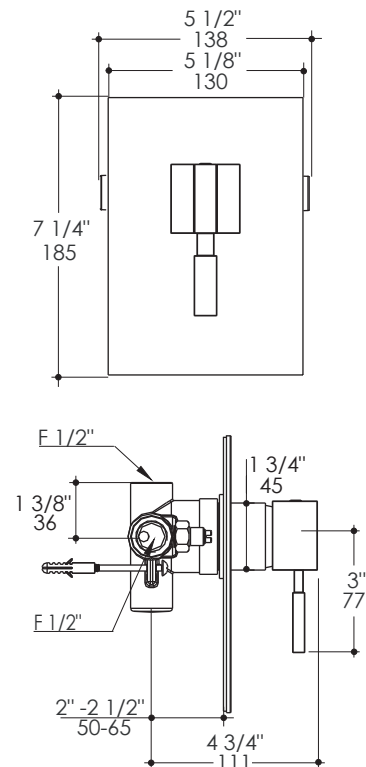

### Notes:

Drawings provided herein are meant to give the user an idea of the product and are not made to scale. The size in inches is rounded up to the nearest 1/16".

LACAVA is committed to the highest level of customer service. Please feel free to contact us at 1-888-522-2827 (toll free) or by email at [info@lacava.com](mailto:info@lacava.com) for technical assistance or any general inquiries.