



2243 S. Throop St.  
Chicago, IL 60608  
[info@lacava.com](mailto:info@lacava.com)  
[www.lacava.com](http://www.lacava.com)

## Owner's Manual

---

**Important:** Keep this manual for future technical assistance and/or replacement parts. Please read the instructions within the booklet carefully prior to installation. LACAVA recommends that this fixture be installed by a professional plumber and will not be held responsible for any damage caused by improper installation. It is the responsibility of the homeowner to ensure that this fixture complies with all local plumbing codes. Please see our Terms and Conditions found in this booklet for additional information. For technical assistance please contact: 888-522-2823 (toll free).

Please reference this number:

PS#:

## Table of Contents

Page 2: Warranty  
Page 2: Cleaning & Care Instructions  
Page 3: Parts Breakdown  
Page 4: Installation Instructions  
Page 6: Product Specifications  
Page 7: Terms and Conditions

### **Waterblade Wall Mounted Bath Filler w/ Two Way Diverter Item #W1030**



## Warranty

LACAVA warrants its products to be free from any defects in materials or workmanship, during normal residential or commercial use, including all hinges, drawer slides, cartridges, finishes, and general workmanship of the item. LACAVA warranties do not cover normal wear and tear, damages due to negligence, improper installation, alterations, improper repairs, improper use, improper maintenance, or damages due to uses of the product other than its intended and normal use. All warranties last for a period of one year from the date of purchase. If a defect is found under normal use, while under warranty, LACAVA will repair or replace the product (whichever cost is smaller to LACAVA) at its own expense (excluding shipping and installation charges). Under no circumstances is LACAVA responsible for installation/service fees or any dollar amount beyond the cost of the item. In addition, all LACAVA products are to be installed by experienced professionals properly licensed and bonded; otherwise, any LACAVA warranty and liability is to be considered waived. All warranties are non-transferable and proof of purchase is required for any warranty claim.

In accordance with the laws of limitation and exclusion state by state, and therefore provided the duly exceptions, LACAVA will not be held liable, in any event, for any special, indirect, incidental or consequential damages or losses (including but not limited to damages for loss of business, loss of profits, etc.) for breach of contract, tort (including negligence), product liability or otherwise, even if it has been advised of the possibility of such damages. LACAVA's liability on any claim (including negligence) will not in any case exceed the contract price paid by the original purchaser for the product claimed defective or unsuitable. It is the responsibility of the homeowner to ensure that all installed fixtures comply with all local plumbing codes.

## Cleaning & Care Instructions

For best results, please care for this product in accordance with the following instructions:

- Only use warm water and a mild detergent (i.e. dishwashing soap) for cleaning.
- If another cleaner is used, check the label to make sure that it is safe for use on the material being cleaned and always test in an inconspicuous area first.
- Make sure to wipe any excess cleaners off with a damp sponge or cloth and then rinse with water.
- Dry the surface with a soft cloth until dry after each use.
- Never use abrasive materials or cleaners that contain ammonia, bleach or acid, since they can cause damage to the finished surface.

*We would like to thank you for your purchase and are confident that you will be able to enjoy our products for many years to come!*

## Parts Breakdown

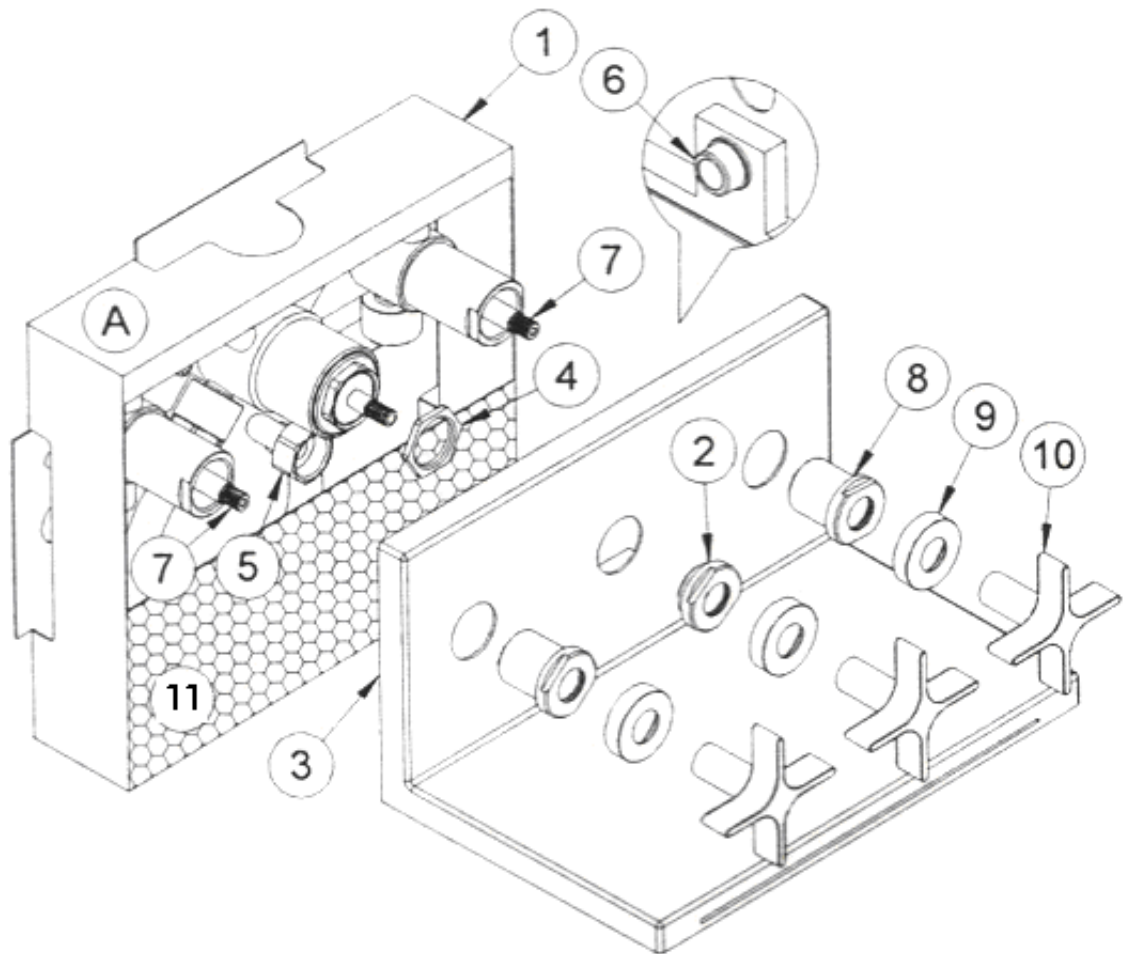

1. Rough-in Assembly
2. Brass Ring
3. Center hole of the Trim-shelf
4. Locking Nut
5. Flexible Supply Lines
6. Supply Line Extensions
7. Ceramic Disc Cartridges
8. Brass Ring
9. Escutcheon Rings
10. Control Handles
11. Rough-in Plate

## Installation Instructions

1. Attach the rough-in plate onto the bottom half of the rough-in assembly by screwing the provided screws through both the holes along the edge of the plate and rough-in box.
2. Place the entire rough-in assembly into the wall and connect the water supply to the bottom inlets, hot on the left and cold on the right. The rough-in assembly must be installed with screws or cement in such a way that side A is perfectly horizontal; otherwise the trims will not be leveled. Once the rough-in is installed adjustments to the external trim will not be possible.
3. Insert a brass ring into the center hole of the trim-shelf and then tighten the locking nut.
4. Attach the flexible supply lines from the rough-in to the extensions on the back wall of the trim shelf.
5. Position the trim shelf on the wall against the rough-in assembly by placing the holes in the trim over the ceramic disc cartridges extending from the wall.
6. Carefully tighten the trim with the brass rings. Warning: Excessive tightening may deform the trim, so be careful not to apply too much pressure.
7. Tighten the escutcheon rings over the brass rings.
8. Place the control handles onto the cartridge extensions. Note: The control handles have a pressure sensitive fixing system, so in order not to wear it out, only the chrome escutcheon rings should be unthreaded for cleaning maintenance.

## Replacement of the Diverter Cartridge

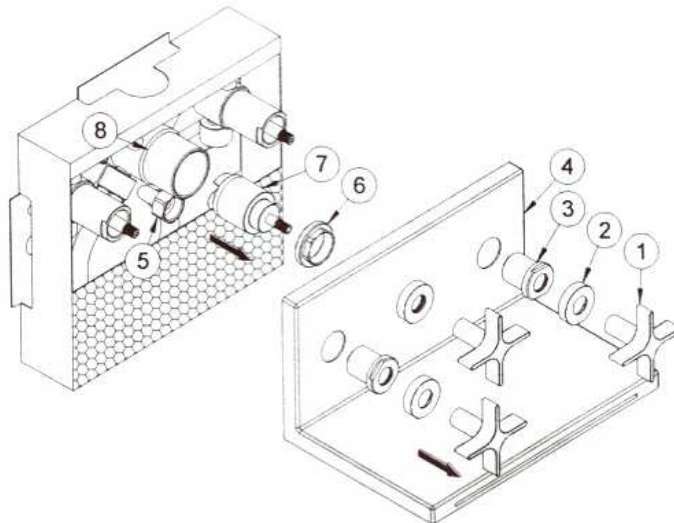

1. Close the water supply lines
2. Remove the control handles (1), unscrew the escutcheon rings (2) and then unscrew the brass rings (3).
3. Remove the trim (4) by detaching the flexible supply lines (5) from the back wall of the trim.
4. Unscrew the ring (6) and remove the diverter cartridge (7) from the body (8).
5. Clean the rear seal area and install the new cartridge (part #R135).
6. Reassemble by reversing instructions 4-2.
7. Open the supply lines and check for any leaks.

## Replacement of the Ceramic Cartridge

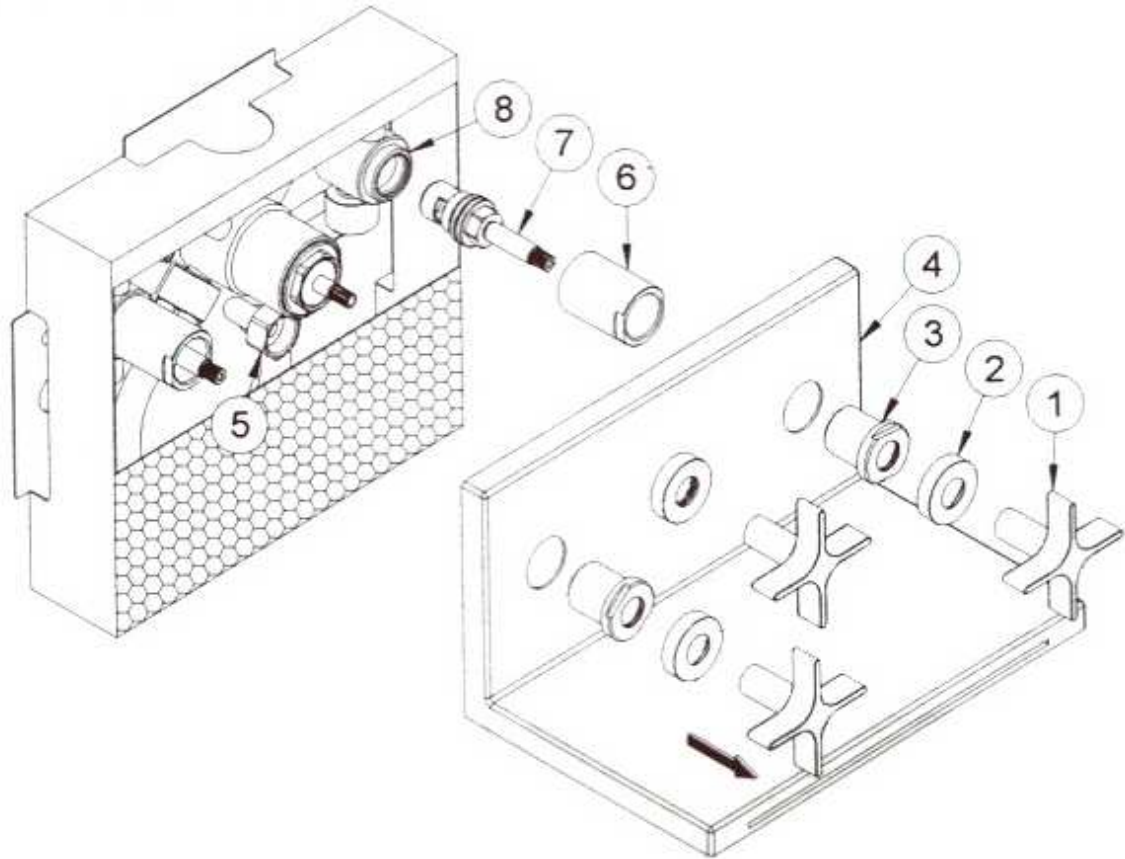

1. Close the supply lines.
2. Remove the control handles (1) as shown.
3. Unscrew the escutcheon rings (2) first and then unscrew the brass rings (3).
4. Remove the trim (4) by detaching the flexible supply lines (5) from the back wall of the trim.
5. Unscrew the brass covers (6) and ceramic cartridges (7) from the body (8).
6. Insert and tighten the replacement cartridges (part #R134) into the cartridge's preset housing.
7. Reassemble by reversing steps 2-5.
8. Open the supply lines and check for any leaks.



# Terms and Conditions

## UNIQUENESS

Many LACAVA products are made of natural stone, woods, or metals. Because of the natural variations, and/or handmade nature of the products, slight differences are expected and are not deemed manufacturing defects.

## SHIPPING POLICIES

Once the merchandise is released to and accepted by the carrier, LACAVA's responsibility ends. LACAVA LLC is not responsible for damages occurring in transit. After the merchandise is delivered and the shipping document is signed, it becomes the property of the purchaser. We constantly improve the packaging as new technologies become available, but damages in transit may still occur. Therefore, we recommend that all packages be inspected by the purchaser in the carrier's presence upon delivery. In case of damages, either visible or concealed, the purchaser is responsible for filing any damage claim against the carrier. In this regretful circumstance, we suggest utter diligence to have the carrier's agent explain the steps to submit a valid claim against the carrier, as each carrier has different claim policies. Please document everything in writing, preferably on the shipping documents and have also the carrier's agent sign along. If you wish that Lacava assists you in the claim process, please fax or email us copies of the shipping and claim documents at your earliest convenience. In the case of missing items, which could occur due to our mistake or a theft during transit, please follow same procedures as for shipping damages above, with the only difference that the claim concerns something completely missing, rather than damaged. Please take note of any visible tampering with the packaging in the presence of the carrier's agent before accepting the delivery with your signature. In case of missing items, you must also inform LACAVA and send us all related documents within 24 hours from the delivery date. We will open an internal investigation and check the inventory count to determine whether it was our error. If we verify it was our mistake, we will promptly ship the missing item(s) to the purchaser by standard ground at our cost.

## RETURN POLICIES

If the product is not satisfactory for any reason different from defects, it can be returned to LACAVA LLC up to 30 (thirty) days from the shipping date after obtaining a Return Goods Authorization (RGA) valid for 60 (sixty) days. If the product is not returned to LACAVA within that timeframe, the RGA will be voided and no further RGAs will be issued for the product. The merchandise must be in salable condition, in its original packaging, and packed safely with the RGA number clearly marked on the outside packaging. To obtain an RGA number, please fax or email the request with a description of the reason for return. The merchandise must be in its original packaging and packed safely in accordance with the carrier's packing requirements, with the RGA number clearly marked on the outside packaging. LACAVA reserves the right not to issue any credit, if an approved RGA number has not been obtained. A restocking fee of 25 percent and applicable shipping charges to the customer and back will be deducted from the credit amount. Credit (excluding shipping and handling charges) will be given only for returns of intact products up to 30 days from the shipping date. After 30 days from the shipping date, no returns will be accepted. All returned merchandise is at the purchaser's risk and cost. Special order and custom made items are not returnable. Products must be inspected prior to installation and installation of the product means its acceptance. Product, once installed, cannot be returned. Damages occurring in installation are not considered defects and are not subject to return or refund. LACAVA will replace any defective item for free only after the non-conforming product is safely returned to LACAVA's warehouse safely in accordance with the carrier's packing requirements, and in its original packaging, within 30 days from the shipping date. If the product is not found to be defective and is damaged in any way, there may be a charge for any replacement. In any case, LACAVA does not cover installation costs.

