



2243 S. Throop St.  
Chicago, IL 60608  
[info@lacava.com](mailto:info@lacava.com)  
[www.lacava.com](http://www.lacava.com)

## Owner's Manual

---

**Important:** Keep this manual for future technical assistance and/or replacement parts. Please read the instructions within the booklet carefully prior to installation. LACAVA recommends that this fixture be installed by a professional plumber and will not be held responsible for any damage caused by improper installation. It is the responsibility of the homeowner to ensure that this fixture complies with all local plumbing codes. Please see our Terms and Conditions found in this booklet for additional information. For technical assistance please contact: 888-522-2823 (toll free).

Please reference this number:

PS#:

## Table of Contents

Page 2: Cleaning & Care Instructions  
Page 3: Warranty  
Page 4: Parts Breakdown  
Page 5: Installation Instructions  
Page 6: Product Specifications  
Page 7: Terms and Conditions

### Arch Wall Mounted Bath Set Item #12330/12333



# Cleaning & Care Instructions

## STAINLESS STEEL

Stainless steel is a very wear-resistant material. In order to achieve maximum corrosion resistance, the surface of stainless steel must be kept clean. Provided that you follow a few simple steps, it will last a lifetime in good condition.

- After each use, wash the sink with water and mild soap detergents; rinse the surface with clean warm water; and dry the sink with a soft dry cloth.
- Do not leave liquids containing chlorine, rusty items, toilet cleaners, acids, concentrated disinfectants, or strong alkalis in the sink for long periods because they may discolor the surface.
- AVOID using coarse abrasive materials such as scouring pads, wire wool, etc. which scratch the surface of polished stainless steel.

NEVER let strong acids come into contact with stainless steel.

**Other Metals (like faucets, chrome brackets, etc.)**. Use pure water for regular care. If the parts are heavily congested, dissolve a couple of drops of dish soap in a small amount of water for cleaning. **Do not use abrasive agents** - they will cause scratches. For best results, rub the surface with a soft cloth until dry.

## GLASS

To prevent the formation of deposits, rinse and dry the glass after each use. To remove permanent water stains, apply any glass cleaning aids and detergents available and/or baking soda(apply directly with a soft cloth and a couple drops of water), like the ones used to clean shower doors, rinse the surface with clean water, and dry with soft dry cloth. **DO NOT** use coarse abrasive materials or sharp objects which may scratch the surface and leave marks on the glass.

## WOOD

Clean the surface with soft cloth using only cleaning agents designated for wood care. To preserve and restore the natural beauty of wood, apply paste wax with a soft cloth once a week and polish the surface until wax evenly spread. NEVER use coarse abrasive materials which will scratch and discolor the surface, and avoid oily agents that can engage in chemical reactions with lacquered surface. Extensive use of water may also discolor and damage the wood surface, so wiping the wood surface dry after each use is highly recommended.

## MARBLE

Marble stone should be treated with marble sealer (we recommend Stoneguard Sealer) at least once a week to prevent staining. Please follow the sealer manufacturer's instructions to assure the best results.

## VITREOUS CHINA

Vitreous china can be cleaned with a range of cleaning agents designated for bathroom maintenance: only strong acids and abrasive agents should be avoided in order to prevent discoloration and scratches in the glazed surface. Wash with detergent and warm water and rinse. Black marks in the glaze created by contact with metal elements can be removed with very fine steel wool. The marks should be damped with water or glass cleaner and rubbed with steel wool until it is removed (this may take longer than a couple of minutes). Lime deposits may be removed by a solution of vinegar and water. Bathroom fixtures should be disinfected weekly with a solution of chlorine bleach and water or a spray-on disinfectant or by using disinfectant cleaning foam. Rust stains can be removed by using commercial rust remover or by using a solution of 1 tablespoon oxalic acid crystals (poison), dissolved in ½ cup warm water. Apply to stain, allowing to stand a few minutes, and then rinse well.

## ACRYLIC & SOLID SURFACE

Acrylic and solid surface is non-porous so liquids cannot penetrate it. Use water with dish soap or an ammonia-based cleanser (such as glass cleanser). Wipe away water stains with a damp cloth and sponge and dry with a towel. Occasionally wipe sinks and bowls with diluted household bleach (1/1 water/bleach solution) to disinfect. Surfaces exposed to acetone-based polish removers and paint removers should be promptly flushed with water. To remove stains, use Soft Scrub(r) diluted bleach and a sponge to rub in circular motion. If the area is dull in contrast with the surrounding surface, use a white polishing compound with a sponge to get a higher gloss. To remove cuts and scratches, sand with 400-grit (30 micron) or 600-grit (20 micron) sandpaper; buff with polishing pad at a low speed (1,500 - 2,000 rpm) polisher equipped with a wool pad; finish with wax.

## Warranty

Lacava does not make any warranties, expressed or implied, except for warranty that our product be free from manufacturing defects in material and workmanship for a period of one year from the date of purchase. If a product is determined to be defective when still under warranty, Lacava will repair or replace the product (whichever cost is smaller to Lacava) at its own expense (excluding shipping and installation charges). The warranty does not cover the normal wear and tear, damages due to negligence, improper installation, alterations, improper repairs, improper use, improper maintenance, or damages due to uses of the product other than its intended and normal use. In accordance with the laws of limitation and exclusion state by state, and therefore provided the duly exceptions, Lacava will not be held liable, in any event, for any special, indirect, incidental or consequential damages or losses (including but not limited to damages for loss of business, loss of profits, etc.) for breach of contract, tort (including negligence), product liability or otherwise, even if it has been advised of the possibility of such damages. LACAVA's liability on any claim (including negligence) will not in any case exceed the contract price paid by the original purchaser for the product claimed defective or unsuitable.

### **Important Information:**

Failure to fully comply with these installation instructions will void your warranty LACAVA LLC is not responsible for any damages resulting from non-compliance with these instructions. Furthermore it is the responsibility of the installer to ensure that this product complies with all local plumbing codes

### **Warranty Conditions:**

1. LACAVA Subjects all its products to quality controls and guarantees them against manufacturing defects. The guarantee covers the free elimination of all faults, as judged by LACAVA, by repair and/or replacement of the product or parts of it. The guarantee covers all countries in which the product is supplied by LACAVA.
2. LACAVA guarantees its products for a period of:
  - 5 years against fusion and porosity faults
  - 5 years against cartridge or bolts faults
  - 5 years for chrome-plating defects
  - 1 year for faults with all other finishes (wood)
  - 1 year for washer or o-rings faults
3. The warranty is acknowledged exclusively if proof of purchase is available in the form of a receipt or invoice bearing the date of purchase and the name of the dealer bought from.
4. Faulty material must be returned to our facility together with proof of purchase and RGA sheet.
5. For the products which have not been installed, the warranty will only be acknowledge if the returned to LACAVA in the original packaging, along with proof of purchase and RGA sheet.
6. The warranty does not cover damages due to :
  - Failure to observe the instructions in this installation booklet and; therefore incorrect installation , improper use , incorrect maintenance
  - Transport and handling
  - Wear of parts (valves, membranes, etc...)
  - Tampering or repairs carried out by anyone other than those authorized by LACAVA, and the use of non-original LACAVA spare parts
  - Frost and foreign bodies inside the pipes
7. The warranty does not cover assembly or disassembly of the product, transfers and technical intervention by authorized personnel.

## Parts Breakdown

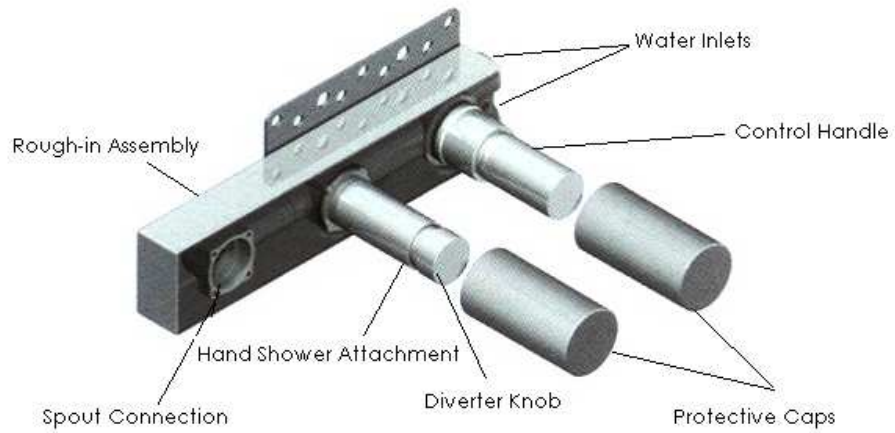

### External Trim for #12333

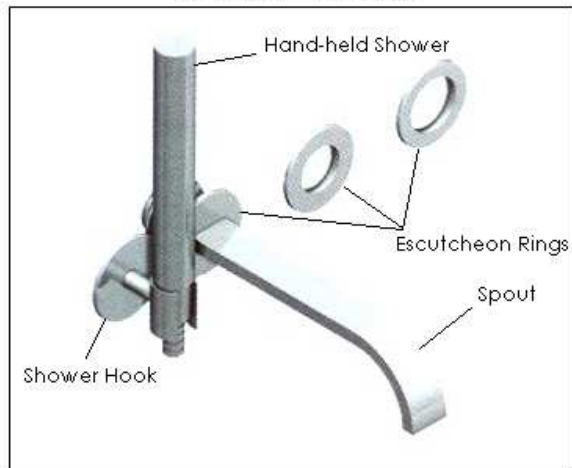

### External Trim for #12330

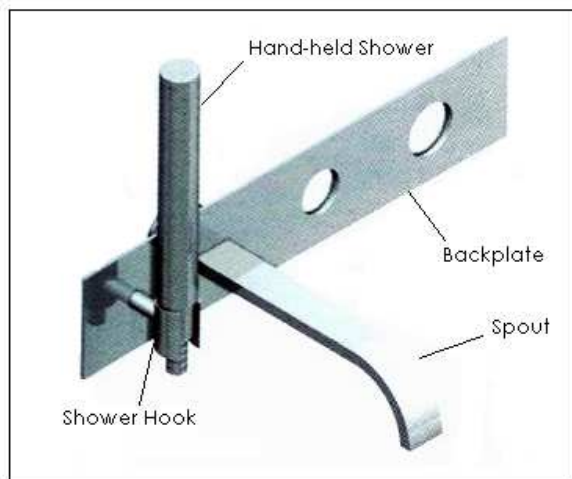

## Installation Instructions

1. Create a hole in the wall for the rough-in assembly.
2. Install the rough-in assembly into the wall, making sure that the finished wall stays in between the lines on the protective cap designating the minimum and maximum levels for the finished wall. Connect the rough-in to the water supply.
3. Remove the four screws from around the spout connection and then push the spout into the designated place on the rough-in
4. Tighten the spout into place by screwing one of the provided screws into each of the four screw holes.
5. *For #12330 only:* Slide an escutcheon ring over the control handle, diverter knob, and the spout. Make sure that all three rings are pressing up against the wall. Then drill a pilot hole for the shower hook, and place the anchor into the pilot hole. Then attach the shower hook to the wall by tightening the provided screw into the anchor.
6. *For #13013 only:* Slide the back plate over the control handle, diverter knob, and spout so that it sits flush with the wall and the shower hook sits to the left of the spout.
7. Screw the hand shower connector into the water intake on the underside of the diverter knob, making sure that the o-ring is intact.
8. Tightly screw one end of the hand shower hose onto the hand shower connector of the diverter knob, and the other end onto the base of the hand shower.

## Product Specifications

#12330:

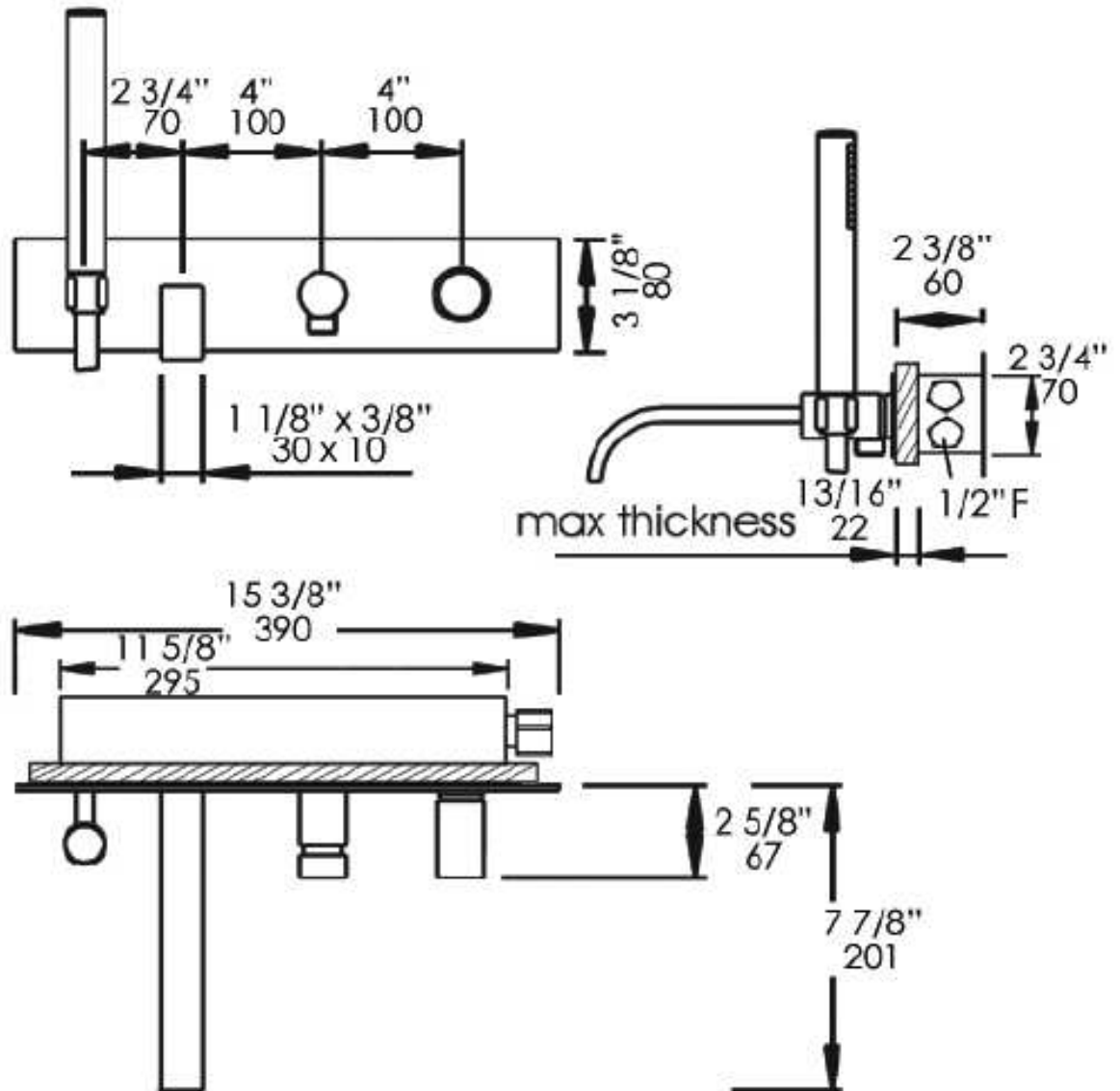

Flow Rate: 3.2 GPM at 29 PSI

Note:

Drawings provided herein are meant to give the user an idea of the product and are not made to scale. The sizes in inches are rounded up to the nearest 1/16. For further information, refer to the installation instructions included with your shipment.

## Product Specifications

#12333:

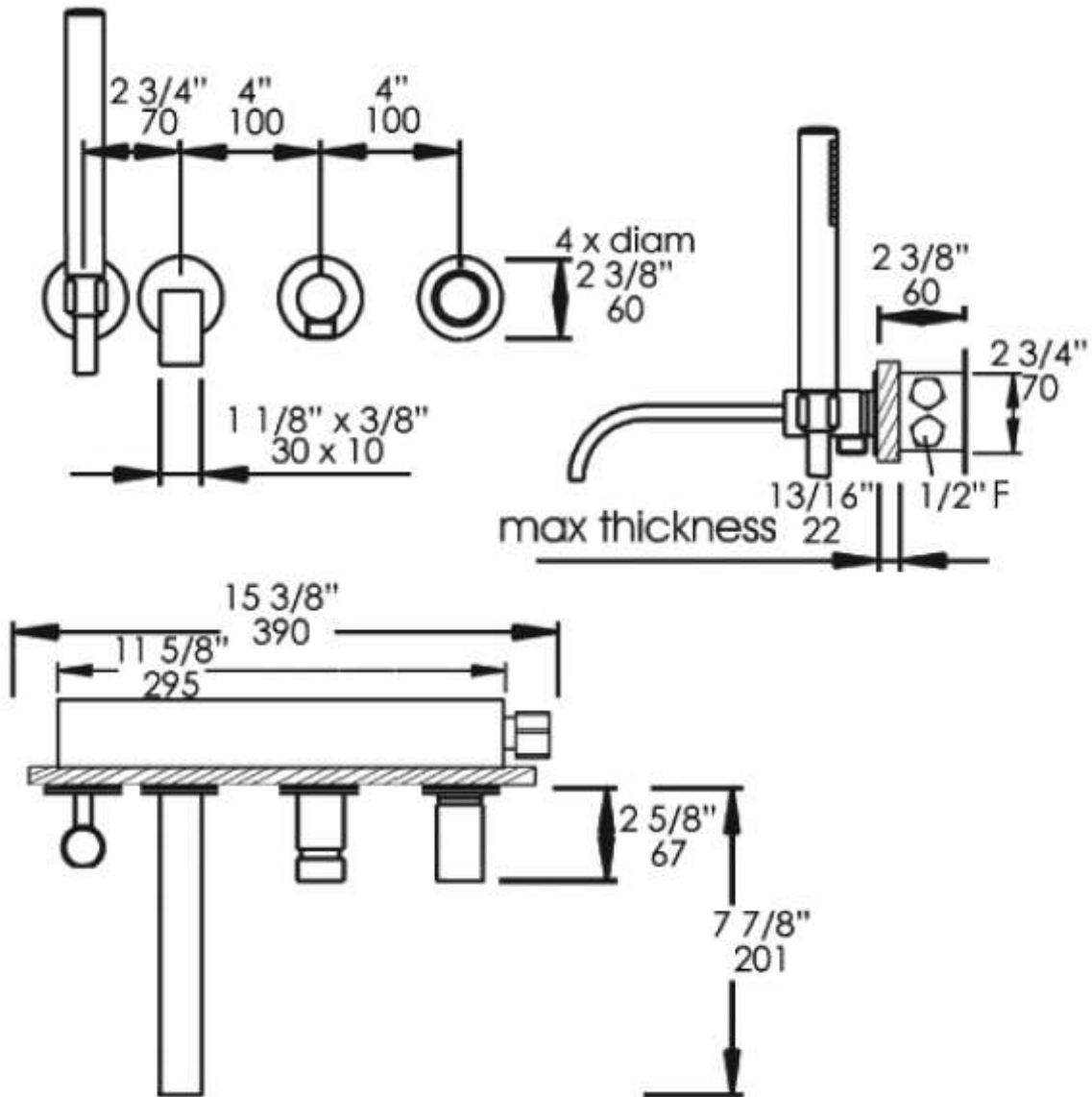

Flow Rate: 3.2 GPM at 29 PSI

Note:

Drawings provided herein are meant to give the user an idea of the product and are not made to scale. The sizes in inches are rounded up to the nearest 1/16. For further information, refer to the installation instructions included with your shipment.

# Terms and Conditions

## UNIQUENESS

Many products are made of natural stone, woods, or metals. Because of the natural variations, and/or handmade nature of the products, slight differences are expected and are not deemed manufacturing defects.

## SHIPPING POLICIES

Once the merchandise is released to and accepted by the carrier, LACAVA's responsibility ends. LACAVA LLC is not responsible for damages occurring in transit. After the merchandise is delivered and the shipping document is signed, it becomes the property of the purchaser. We constantly improve the packaging as new technologies become available, but damages in transit may still occur. Therefore, we recommend that all packages be inspected by the purchaser in the carrier's presence upon delivery. In case of damages, either visible or concealed, the purchaser is responsible for filing any damage claim against the carrier. In this regretful circumstance, we suggest you be very conservative and have the carrier's agent explain the steps to submit a valid claim against the carrier (as each carrier has different claim policies). Please document everything in writing, preferably on the shipping documents and have also the carrier's agent sign along. If you wish for us to assist you in the claim process, please fax us copies of the shipping and claim documents at your earliest convenience. In the case of missing items, since we don't know whether it is due our mistake or a theft during transit, please follow same process as above for shipping damages, with the only difference being that the claim will be about something completely missing, rather than damaged. Please take note, in the presence of the carrier's agent, any visible tampering with the packaging. In case of missing items, you also have to inform LACAVA and send to LACAVA all related documents within 24 hours from the delivery date. We will open an internal investigation and check the inventory count to determine if it was an error on our part. If we realize it was our mistake, we will promptly ship the missing item(s) to the purchaser by standard ground at our cost.

## RETURN POLICIES

LACAVA will replace any product non-conforming with ordered product due to production defects only after the non-conforming product is returned to LACAVA's warehouse in salable condition within 30 (thirty) days from the shipping date. In any case, LACAVA does not cover installation costs. If the product is not satisfactory for any reason different from defects, it can be returned to LACAVA LLC up to 30 (thirty) days from the shipping date after obtaining a Return Goods Authorization (RGA) valid for 60 (sixty) days. If the product is not returned to LACAVA within that timeframe, the RGA will be voided and no further RGAs will be issued for the product. The merchandise must be in its original packaging and packed safely. A restocking fee of 25 percent and applicable shipping charges to the customer and back will be deducted from the credit amount. Credit (excluding shipping and handling charges) will be given only for returns of intact products up to 30 days from the shipping date. After 30 days from the shipping date, no returns will be accepted. All returned merchandise is at the purchaser's risk and cost. Special order and custom made items are not returnable. Products must be inspected prior to installation and installation of the product means its acceptance. Product, once installed, cannot be returned. Damages occurring in installation are not considered defects and are not subject to return or refund.

